

Item	Qty.	Description
1	1	23" w x 38" h LT Panel
2	1	38" h LT 90° Corner Connector
3	1	14.125" w x 38" h LT Panel
4	1	38" h LT 90° Corner Connector
5	1	23" w x 38" h LT Panel w/ Door
6	1	38" h LT 90° Corner Connector
7	1	14.125" w x 38" h LT Panel
8	1	38" h LT 90° Corner Connector
1,1A	1,1	35" S44 Vertical Extrusion

**Steps:**

Refer to the LT Panel Assembly general information page.

- 1) Assemble panels & connectors [1] through [10] in numerical order as shown.
- 2) Connect verticals [1-1A] together. See [S44 Connection](#) detail.
- 3) Attach vertical assembly [1/1A] to panel [5] using screw caps.
- 4) Affix **Shelf Supports** to inside of counter assembly; place **Shelf** onto supports.
- 5) Slide Counter Top over vertical assembly [1/1A] & secure to top of counter assembly. See [Counter Top Attachment](#) detail.
- 6) Install Monitor Mount to vertical [1/1A]. See [Monitor Mount Attachment](#) detail.

When assembled

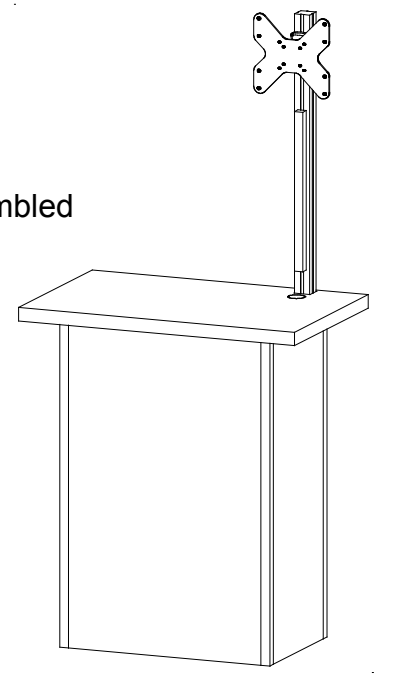

**\* Monitor Mount Attachment**

Slide V4 Connectors into groove of Extrusion. Tighten Set Screws to secure connectors in place.

Attach Monitor Mount back piece to Extrusion, using bolts.

Then slide monitor mount into back piece.

**PR63 Attachment**

- 1) Run cords through PR63 plastic conduit.
- 2) Attach conduit where indicated by pinching the opening and inserting into the groove of extrusion.

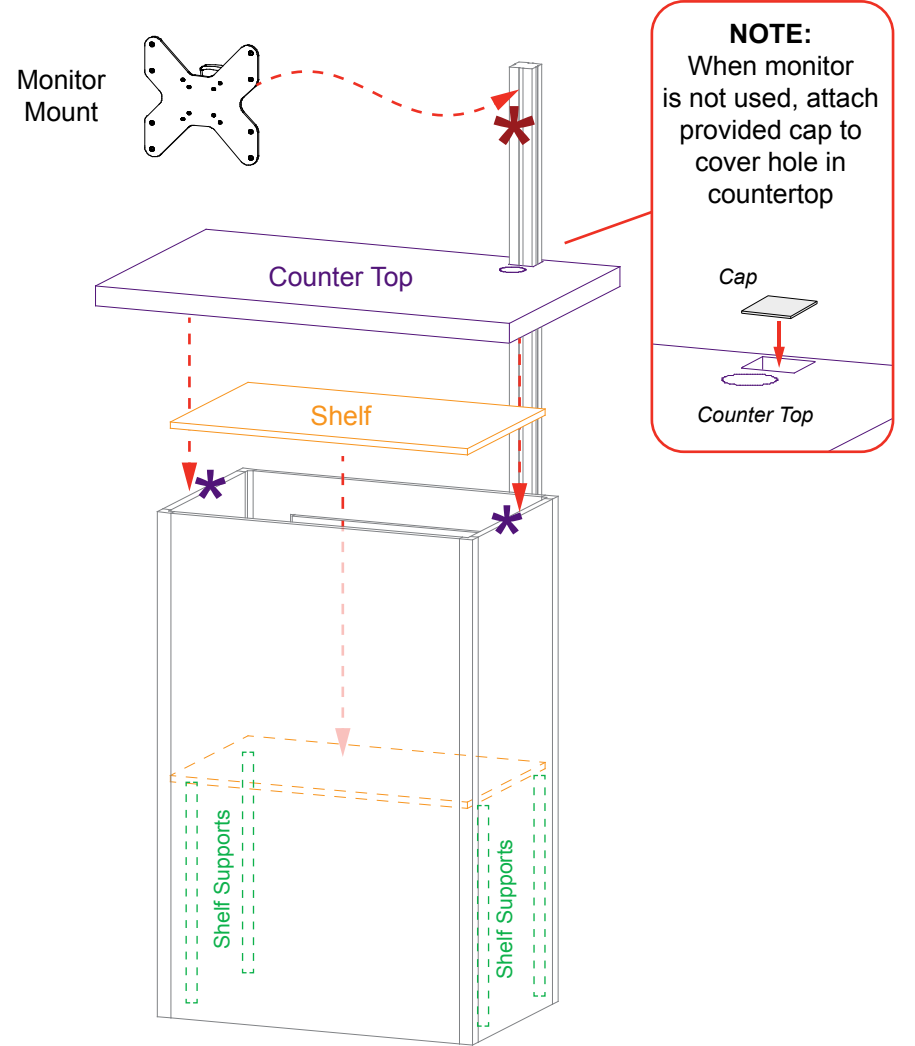
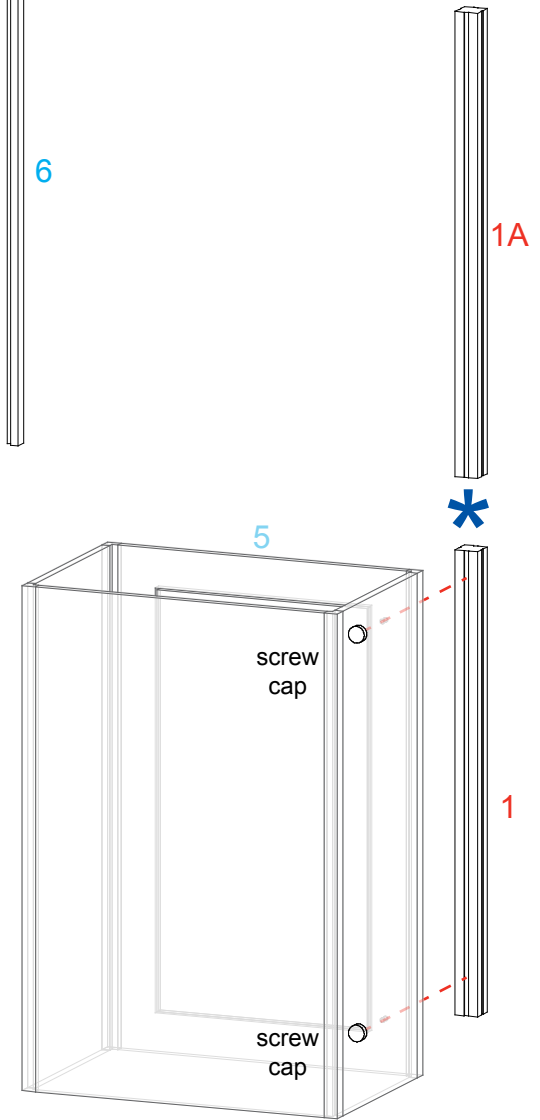
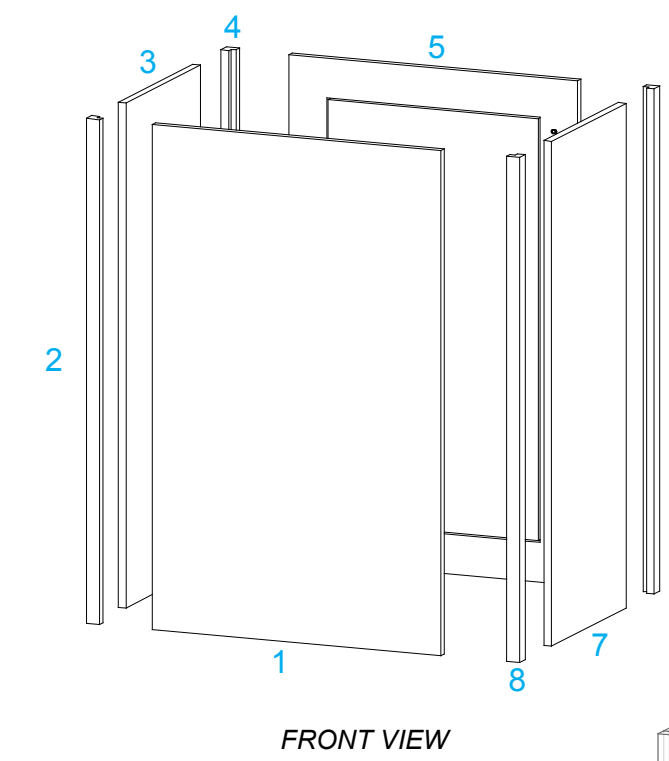

**\* S44 Connection**

Slide extrusion over connector and rest on lower vertical; secure with screws.

**\*\*To prevent product loss, Keep all screws attached to connector piece after disassembling**

**\* Counter Top Attachment**

- 1) Align hole with pin.
- 2) Rotate pin. Spring will push pin into hole.

**SETUP INSTRUCTIONS**

## General Setup Instructions

- Read entire setup instruction manual prior to unpacking parts and pieces.
- The setup instructions are created specifically for this configuration.
- Setup instructions are laid out sequentially in steps, including exploded views with detailed explanation for assembly.

## Cleaning & Packing

- For Cleaning Metal, Plex, & Laminate Parts: Use a **MILD NON-ABRASIVE** cleanser and soft cloth/paper towel to clean all surfaces.
- Keep exhibit components away from heat and prolonged sun exposure.  
**Heat and UV exposure will warp and fade components.**
- Retain all provided Packing Materials. All provided packing materials are for ease of repacking & component protection.

## Disassembly

- For loss prevention, tighten all set screws and locks during disassembly.

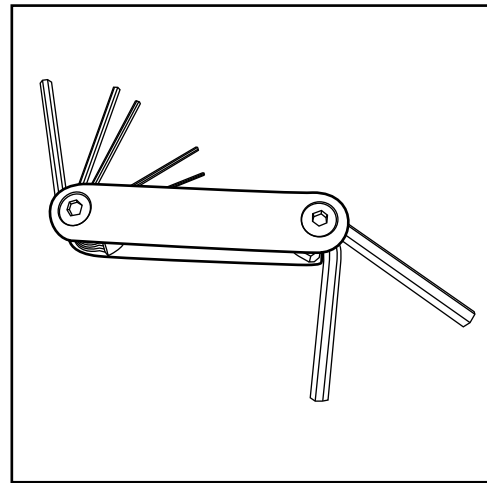

Hex Tool - Essential for Assembly

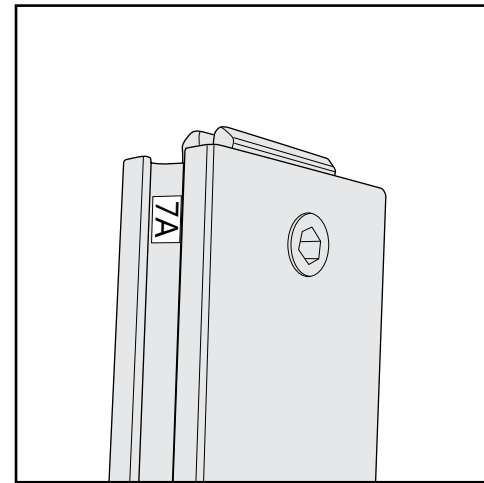

Part Identification - Numbering

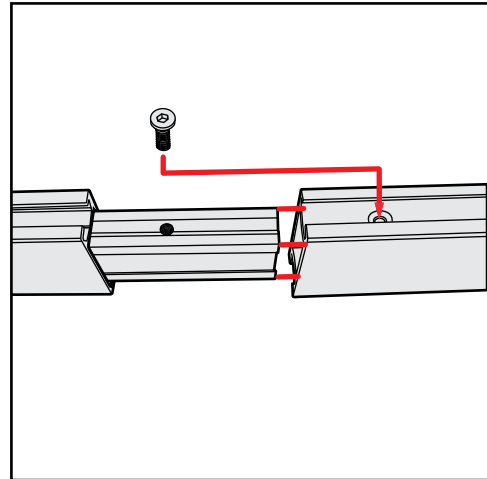

Spline Connection

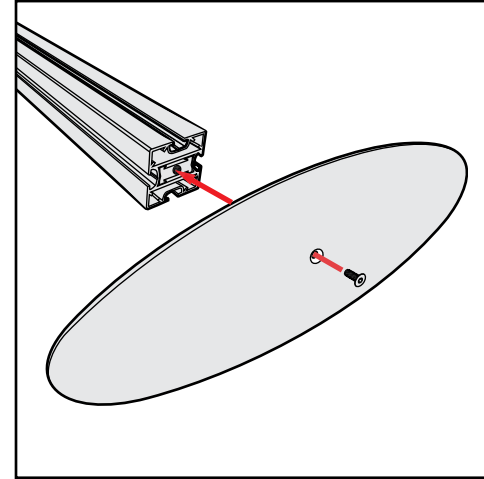

Base Plate & Extrusion Connection

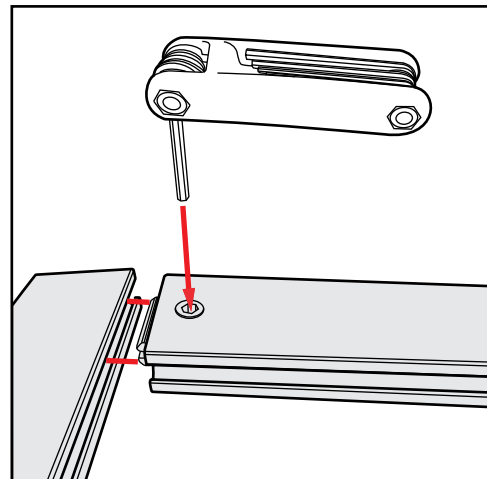

Extrusion & Lock Connection

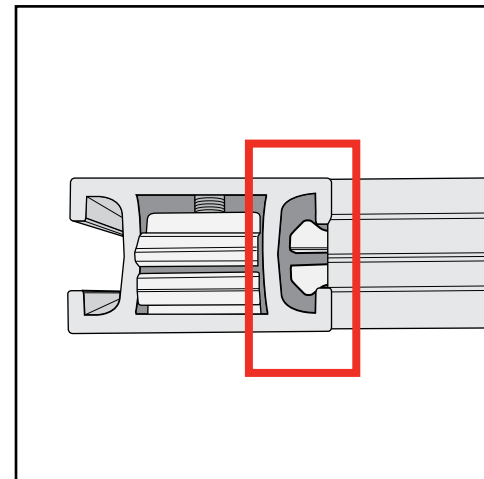

Engaged Lock



**WARNING**



DO NOT USE POWER TOOLS



LADDERS OR LIFTS  
MAY BE REQUIRED



ALL CONNECTIONS MUST  
BE TIGHTLY SECURED

## LT Panel Assembly

- 1) With a vertical offset, place LT-Panels side-by-side; slide vertically offset panel down to lock panels together and in place.
- 2) Corner Connectors (90°, T-Connector, Straight Connector) connect just as panels connect together. Repeat Step 1 for installing corner connectors to panels.

## LT Panel Disassembly

- 1) To disassemble push panel with upper locks horizontally to disengage top lock clip.
- 2) Slide panels or connectors vertically in opposing directions to release latches and disconnect parts.

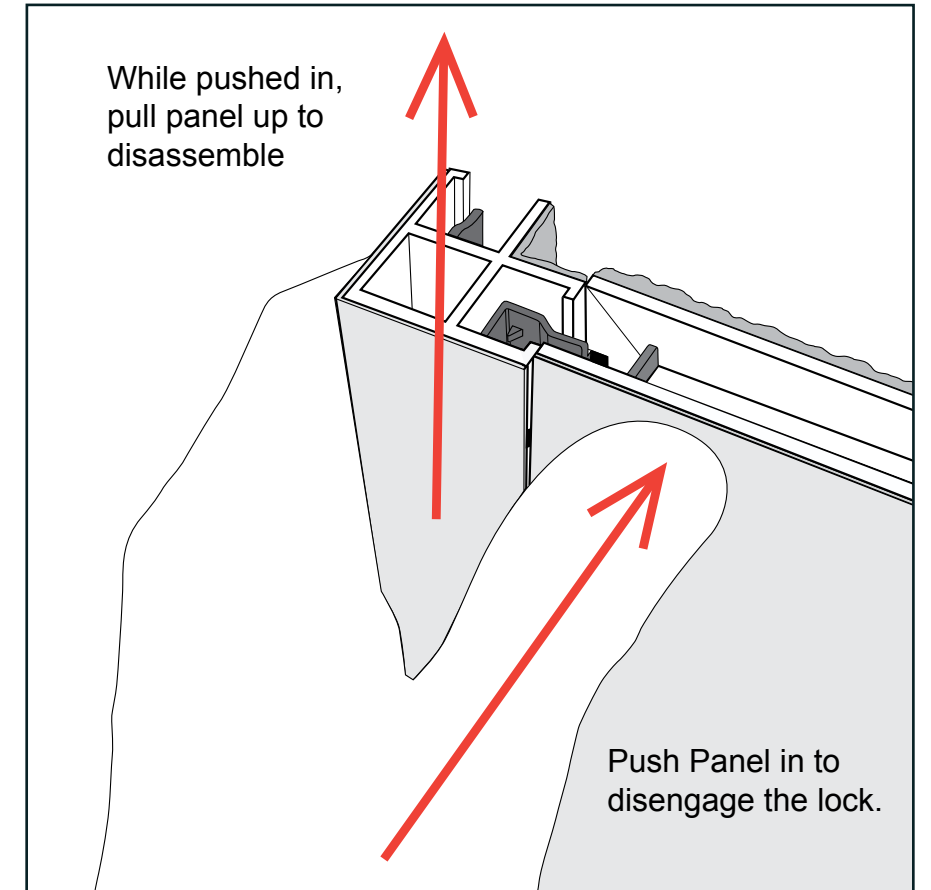
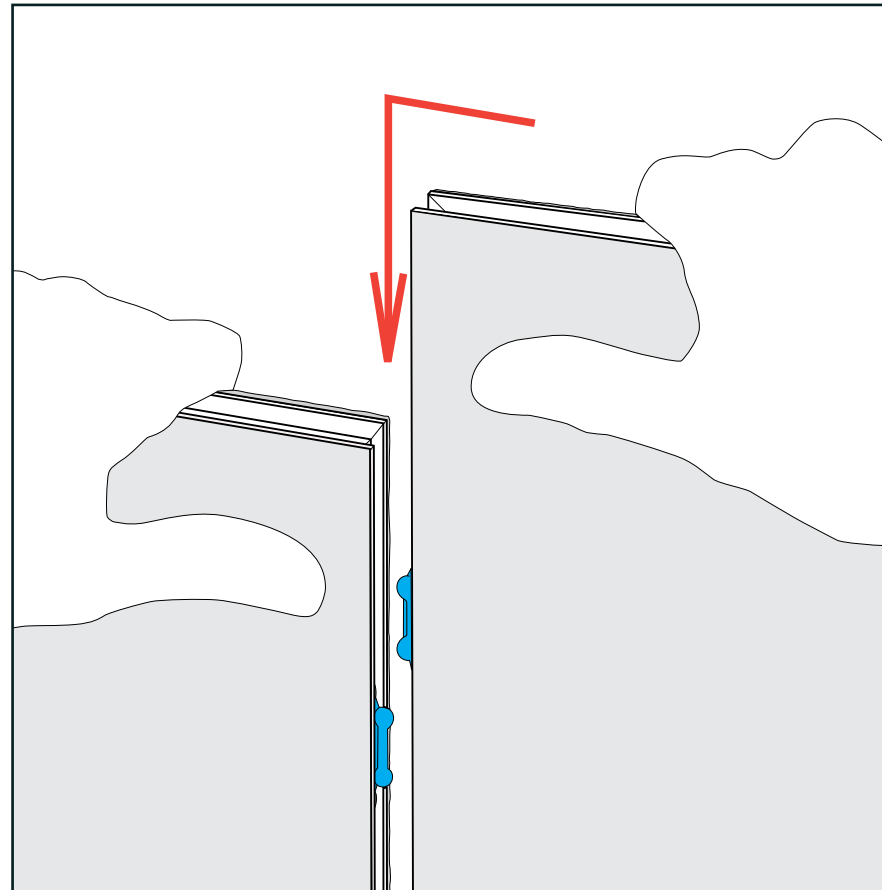

### Top View of Each Level

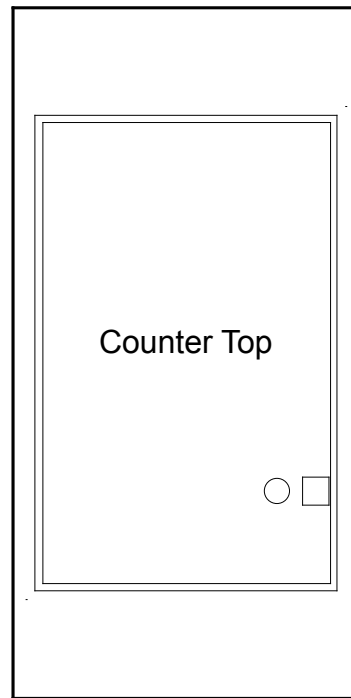

Level 1  
(Bottom level)

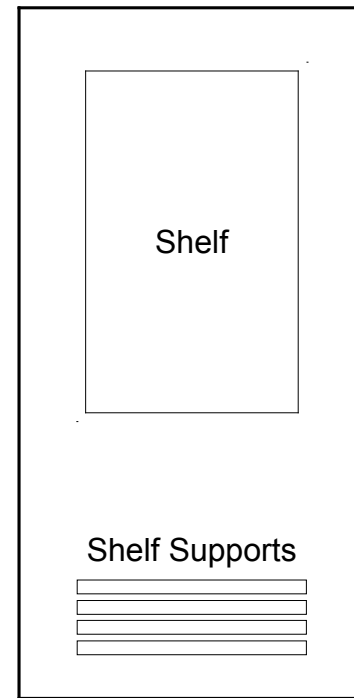

Level 2

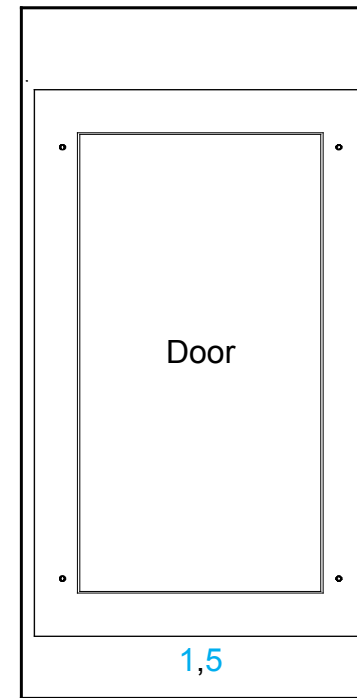

Level 3

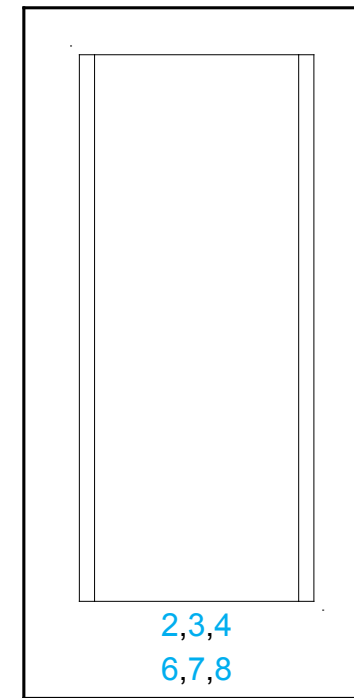

Level 4

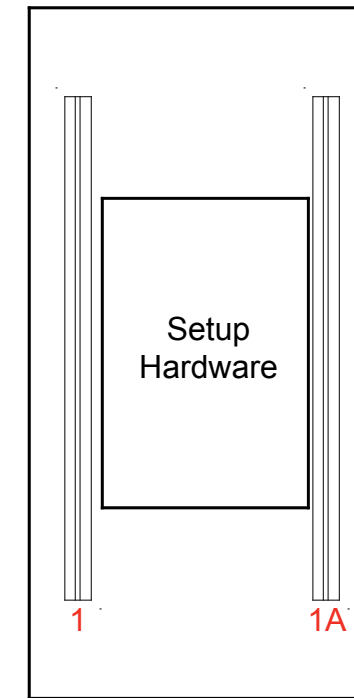

Level 5